

Double Entry Bike Stor



DIMENSIONS	DIMENSIONS (approx.)
Height	1336mm 4ft 5"
Width	1012mm 3ft 3"
Length	1911mm 6ft 3"
Door Aperture Width	943mm 3ft 1"
Door Aperture Height	1195mm 3ft 11"
Weight	170kg

Dark Grey
SFSB002-315

Ivory / Cream
SFSB002-316

Clay Brown
SFSB002-317

Fir Green
SFSB002-318

Lakeland Green
SFSB002-319

Description:

Our double entry bike storage unit can be accessed from both ends of the unit and features an interior galvanised steel divider panel. Both doors lock independently from each other and feature an anti-pick and drill multi-point locking system with internal locking points ensuring that two bikes can be stored securely inside the same unit but completely separate from each other.

This storage unit is ideal for sharing bike storage without compromising on security. Designed to save space, the double entry bike store is ideally suited for areas where space is restricted but bike security is important. As access both ends so the size (width) of the unit is kept to a minimum - ideal for use down the side of a house or flat. Ideal for house/flatshares and rental properties.

This unit comes with simple assembly instructions and a 10 year warranty.

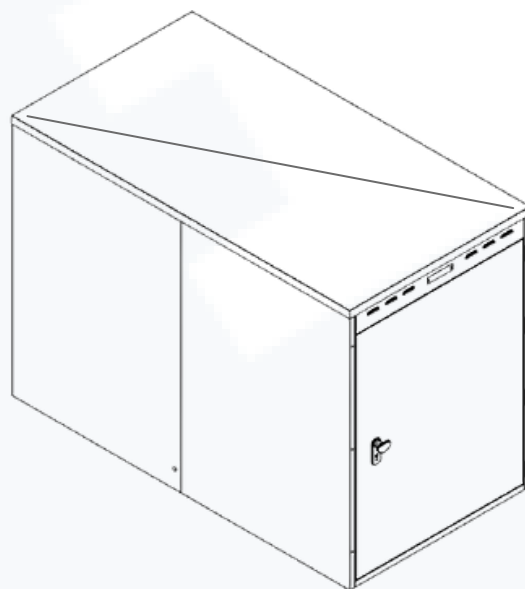

Material & Design:

Built from heavy-duty galvanised steel panels, this unit is completely weatherproof & won't rust or leak. All storage units are designed with the fixtures within the unit to eliminate break-in points, and an anti-pick locking system to deter thieves. The clever design also incorporates a ventilation system to keep stored items in excellent condition free from condensation & damp.

✓ **Ventilation System**
minimise condensation & damp

✓ **Multi-Point Locking System**
with anti-pick & drill properties

✓ **Integrated Metal Floor**
sturdy & secure

✓ **Galvanised Steel**
durable & weatherproof

✓ **Made in the UK**
with a 10 year warranty